

EBV Series - 2-Way & 3-Way, 1/2" - 2"

IOM Manual



Table of Contents

EBV Series - Installation, Operation and Maintenance Manual

Technical Specifications	2
Safety Instructions	3
Product Description/Function	3
Installation/Mounting Positions	4,5
Piping Schematics	6
Dimensions	7-8

**FOR MORE INFORMATION ON THIS PRODUCT
AND OTHER BRAY PRODUCTS**
PLEASE VISIT OUR WEBSITE - www.braycommercialdivision.com

Technical Specifications - EBV Valve Body			
Service	Hot Water, Chilled Water, Condenser Water up to 60% Glycol 15 psig (103 kPa) Saturated Steam @ 250°F for HVAC Systems		
Size Range	2-Way & 3-Way - 1/2" through 2" (DN 15 to 50)		
Valve Body Pressure/ Temperature Rating	Cold Working Pressure	580 psi (PN 40)	
	Water (with Standard Mounting)	-20°F to 203°F @ 580 psi (-29°C to 95°C)	
	Water (with "High Temp" Mounting)	-20°F to 284°F @ 464 psi (-29°C to 140°C)	
	Saturated Steam (with "High Temp" Mounting)	15 psig (103 kPa) at 250°F (121°C)	
Maximum Recommended Operating Pressure Drop	50 psid Maximum Differential Pressure for Valves with Characterized Flow Control Disk and 30 psid Maximum for Quiet Service Ball Valves		
Flow Characteristics	2-Way	Equal Percentage	
	3-Way	Equal Percentage Port A, Linear Port B (Bypass)	
Rangeability	Greater than 500:1 (No disc)		
Ambient Conditions	See Actuator Specifications		
Close-Off	200 psi		
Leakage	Control Port - ANSI/FCI 70-2 Class VI Bypass Port < 1% of Maximum Flow		
End Connections	NPT Threaded, Sweat & Press, BSPP		
Materials	Body	Forged Brass	
	Ball	300 Series Stainless Steel	
	Stem		
	Seats	RPTFE - 15% Graphite Reinforced with EPDM O-Ring Backup	
	Stem Seals	EPDM Double O-Rings	
	Characterizing Disk	AMODEL® AS-1145HS Polyphthalamide Resin	
Weights (NPT) (Valve Body Only)	Size	2-Way	3-Way
	1/2"	0.71 lb. (0.32 kg)	0.79 lb. (0.36 kg)
	3/4"	0.75 lb. (0.34 kg)	0.93 lb. (0.42 kg)
	1"	1.30 lb. (0.59 kg)	1.59 lb. (0.72 kg)
	1-1/4"	2.05 lb. (0.93 kg)	2.56 lb. (1.16 kg)
	1-1/2"	2.73 lb. (1.24 kg)	3.37 lb. (1.53 kg)
	2"	4.61 lb. (2.09 kg)	5.80 lb. (2.63 kg)
Compliance CRN	OC25972		
Warranty	5 Years limited from time of shipment.		

Disclaimer - The performance specifications are nominal and conform to acceptable industry standards. For application at conditions beyond these specifications consult the local Bray office. Bray, Inc. shall not be liable for damages resulting from misapplication or misuse of its products.



Safety Instructions - Definition of Terms Read, Follow and Save these instructions



WARNING

Indicates a potentially hazardous situation which, if not avoided, could result in death or serious injury.



CAUTION

Indicates a potentially hazardous situation which, if not avoided, may result in minor or moderate injury.

NOTICE

Used without the safety alert symbol indicates a potential situation which, if not avoided, may result in an undesirable result or state, including property damage.

Qualified Personnel

A qualified person in terms of this document is one who is familiar with the installation, commissioning and operation of the device and who has appropriate qualifications, such as:

- Is trained in the operation and maintenance of electric equipment and systems in accordance with established safety practices.
- Is trained or authorized to energize, de-energize, ground, tag and lock electrical circuits and equipment in accordance with established safety practices.

- Is trained in the proper use and care of personal protective equipment (PPE) in accordance with established safety practices.

- Is trained in first aid.

- In cases where the device is installed in a potentially explosive (hazardous) location – is trained in the operation, commissioning, operation and maintenance of equipment in hazardous locations.

Product Description

The EBV Series characterized ball valves provide accurate and cost effective control of a wide range of equipment in HVAC applications.

The EBV Series features a forged brass 2-piece body with Stainless Steel balls and stems for water temperature up to 284°F (140°C) and saturated steam up to 15 psig.

IMPORTANT: Use the EBV Series as an operating control. Where failure or malfunction of the EBV Series Valve could lead to personal injury or property damage to the controlled equipment or other property, additional precautions must be designed into the system. Incorporate and maintain other devices, such as supervisory or alarm systems or safety or limit controls, intended to warn of or protect against failure or malfunction of the EBV Series.

IMPORTANT: Take care to prevent foreign material such as weld slag, thread burrs, metal chips, and scale from entering the piping system. This debris can damage or severely impede the operation of the valve by embedding itself in the seats, scoring the valve, and ultimately resulting in seat leakage. If the debris becomes embedded in the seats, subsequent flushing and filtering of the piping system with the valve installed does not remedy the problem.

IMPORTANT: Contact your local Bray representative for compatibility concerns before using EBV Series to control the flow of fluids other than those outlined in the Technical Specifications table in this document.



Installation

Install EBV Series Ball Valves with the actuator at or above the centerline of the horizontal piping, as shown in Figure 1.

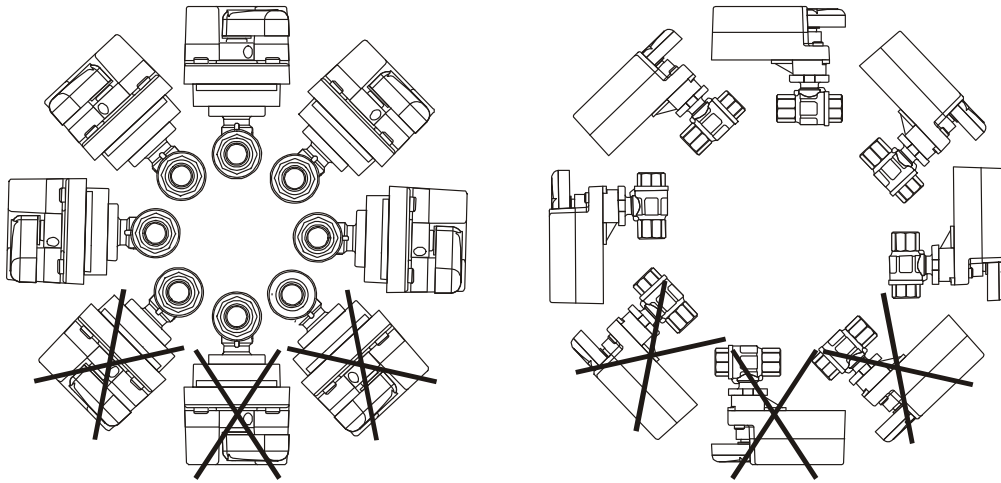

Figure 1: Mounting Positions for Chilled Water and Condensing Atmosphere Applications

Port Configurations

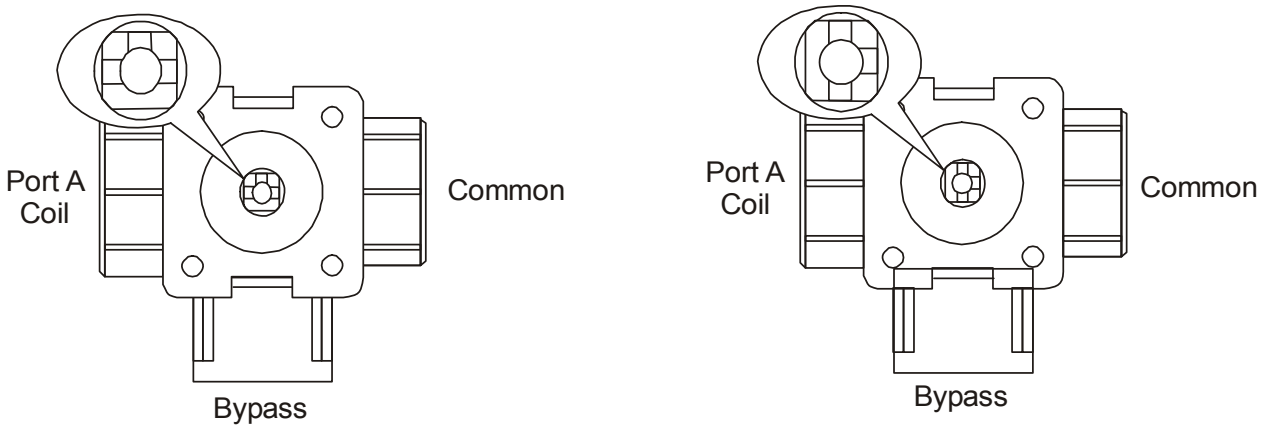

Figure 3: EBV Series Three-Way Ball Valve (Port B Connected to Port C)

IMPORTANT: Protect the actuator from dripping water, condensation, and other moisture. Water or moisture could result in an electrical short, which may damage or affect the operation of the actuator.

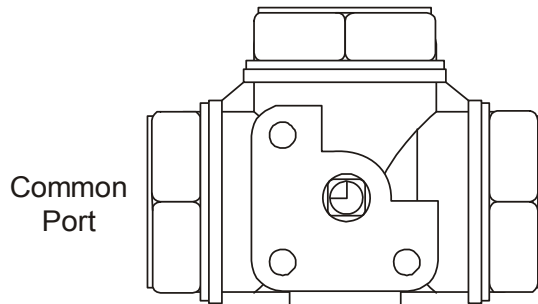

Figure 4: EBV Series Three-Way Ball Valve (Top View)

IMPORTANT: Do not cover the actuator with thermal insulating material. High ambient temperatures may damage the actuator, and a hot water pipe, steam pipe, or other heat source may overheat it.



Press Valve Installation

EBV Series press end connection valves are installed using RIDGID® press tools. Always refer to the operator's manual supplied with the RIDGID press tool that is used to make the valve end connections. The manual should provide proper instructions for the safe operation of the tool, proper crimping procedures, and methods of inspecting the finished connection. If you use a battery-operated press tool, ensure its proper operation by fully charging the unit. To avoid damage to the integral O-ring, never use sealant or pipe dope with a press connection. Always inspect the end connections of the valve before making the connection. The end connection should not be deformed, and the internal, integral O-ring must be in place for a proper seal.

Wiring

Be sure to wire the input lines to the electric actuator correctly for the valve to move in the proper direction.

IMPORTANT:

Use copper conductors only. Make all wiring connections in accordance with local, national, and regional regulations. Do not exceed the actuator's electrical ratings.



WARNING

Risk of Electric Shock.

Disconnect the power supply before making electrical connections. Contact with components carrying hazardous voltage can cause electric shock and may result in severe personal injury or death.

Troubleshooting

Servicing the Actuator or Piping System

When servicing the electric actuator or the piping system:

- Disconnect the power supply to the actuator.
- Relieve the pressure in the piping system.

Sweat Valve Installation

When soft soldering sweat ball valves, be sure to use a low temperature solder with a melting point that does not exceed 450°F (232°C). For lead-free RoHS compliance, a 96.5% tin/3.5% silver solder is recommended. Never install the actuator on the valve until you have completed the soldering operation and the valve body has cooled. Before soldering, minimize the risk of damage to the ball seals by positioning the ball so that Port A is fully open. When soldering, always apply a wet rag around the valve's neck and cover as much of the valve body with the rag as possible. Direct the tip of the flame away from the valve and always heat the copper tubing directly, but never the valve body. Solder Port A first, then the remaining ports. These steps provide maximum protection to the internal valve components. See Figure 5 for details.

Figure 5: Sweat Valve Installation

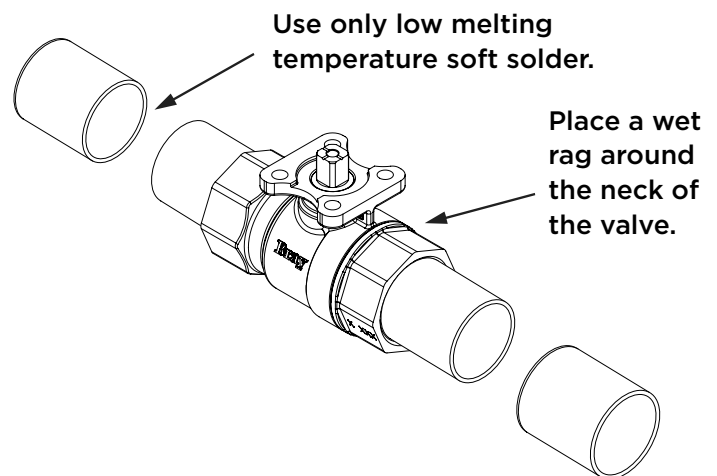

IMPORTANT:

Do not attempt to manually rotate the drive shaft while the actuator is installed without first releasing the actuator gears. Manually rotating the drive shaft without releasing the actuator gears may result in permanent damage to the actuator.



Caution

Risk of Property Damage.

Do not apply power to the system before checking all wiring connections. Short circuited or improperly connected wires may result in permanent damage to the equipment.



EBV Series - Installation, Operation & Maintenance Manual Continued

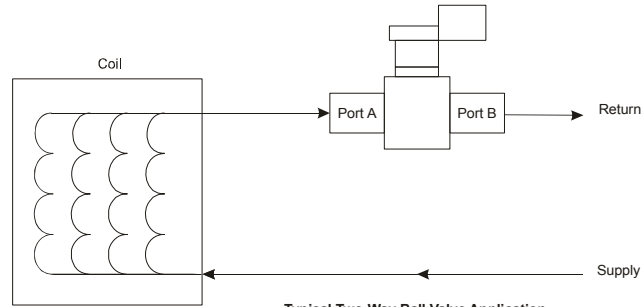

Typical Two-Way Ball Valve Application

Note: Mount the valve downstream from the coil to minimize heat transfer to the actuator.

2-Way - Default Configuration for EBV Series Ball Valves			
Valve Position at Actuator Position	2-Way Non-Spring Return	2-Way Spring Return N.O. (Normally Open)	2-Way Spring Return N.C. (Normally Closed)
Valve Position w/ Act CCW	Open	Open	Open
Valve position w/Act CW	Closed	Closed	Closed
Valve Position w power removed	Last Position	Open	Closed
Modulating actuator control signal Action (Direct Acting)*	CCW at 0; CW at Max	CCW at 0; CW at Max	CW at 0; CCW at Max

*Proportional **MODULATING** actuators include a switch to field convert from Direct Acting to Reverse Action

EBV Series - 3-Way Piping Schematics

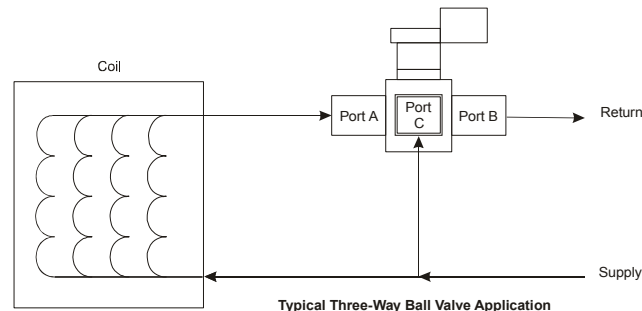

Typical Three-Way Ball Valve Application

Note: Mount the valve downstream from the coil to minimize heat transfer to the actuator. For pure diverting applications (one inlet/two outlets), only the standard port (no characterization disc) versions will work.

3-Way - Default Configuration for EBV Series Ball Valves			
Valve Position at Actuator Position	3-Way Non-Spring Return	3-Way Spring Return N.O. (Normally Open)	3-Way Spring Return N.C. (Normally Closed)
Valve Position w/ Act CCW	A open to B	A open to B	A open to B
Valve position w/Act CW	C open to B	C open to B	C open to B
Valve Position w power removed	Last Position	A open to B	C open to B
Modulating actuator control signal Action (Direct Acting)*	CCW at 0; CW at Max	CCW at 0; CW at Max	CW at 0; CCW at Max

*Proportional **MODULATING** actuators include a switch to field convert from Direct Acting to Reverse Action

EBV Series - How to Change the Characterized Disc

How to Insert the Characterized Disc through the upstream side of the body. Ensure the disc is oriented properly using the locking feature available in both the disc and body. Secure the disc by inserting the retainer clip into the body using circlip pliers. Make sure the retainer clip is locked in the body groove. Verify the disc and retainer clip are secured and not free to rotate after assembly. The same procedure needs to be followed for assembling the diverter disc as shown in the 3-way assembly below.

2-Way

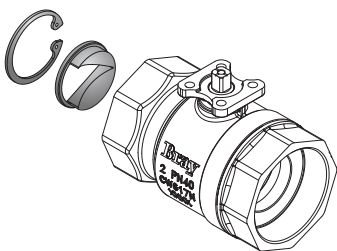

3-Way

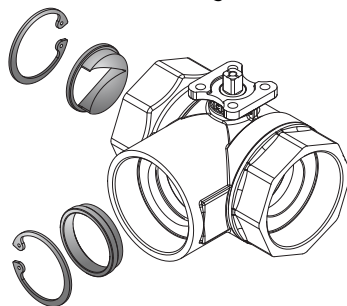

Cv Disc

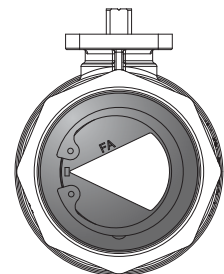



EBV Series - Actuator Dimensions

DCS(M)-20 Series

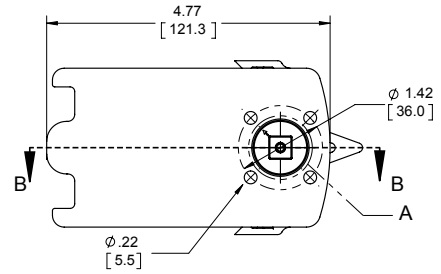
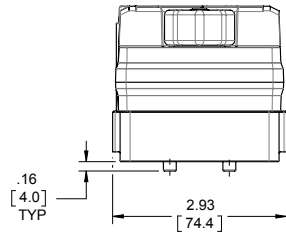
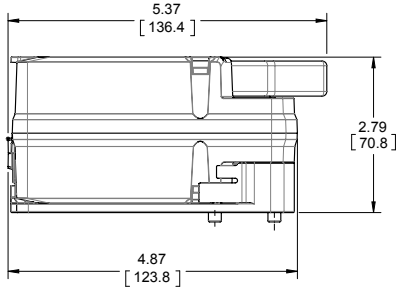

DC(M)-44 Series

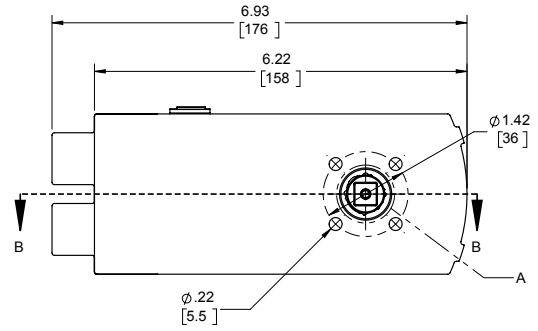
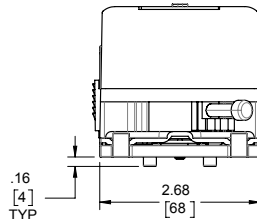
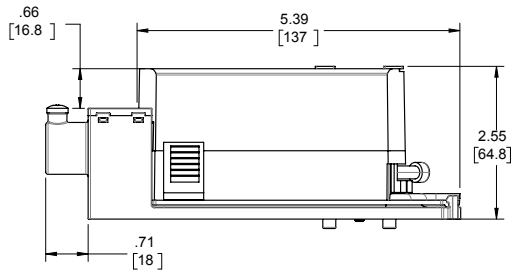

DCS(M)-62 Series

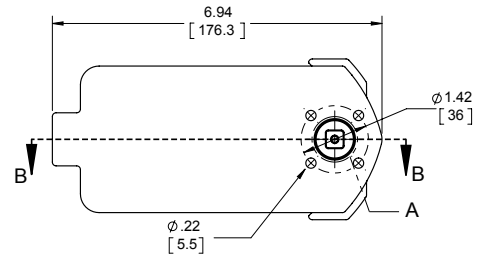
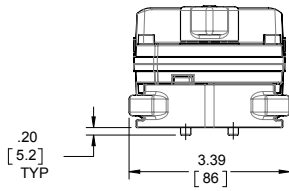
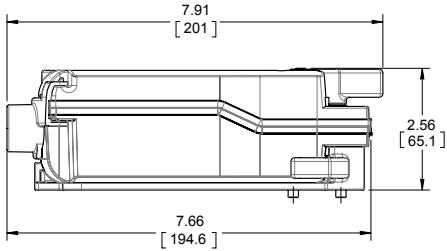

Optional High Temperature Barrier

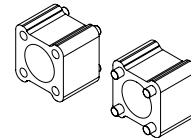
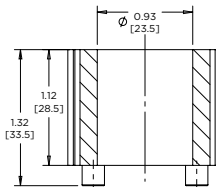
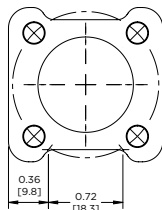
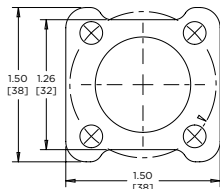



2-WAY

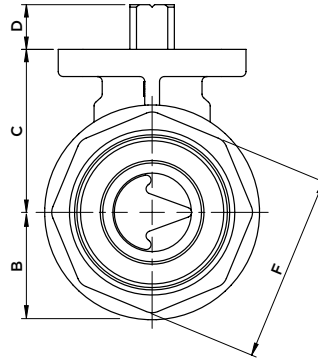
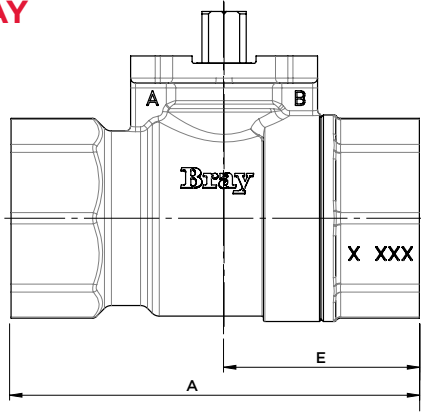

2-WAY - VALVE BODY DIMENSIONS in. (mm)

EBV Valve Model # Prefix	Size		Flow Coefficient		A (NPT)	A (SWEAT/PRESS)	B	C	D	E	F	Weights - lbs. (kg)	
	in.	mm	Cv	Kv								NPT	SWEAT/PRESS
EBV-05-2-x	1/2	15	0.3-17.2	0.3-14.9	2.60 (66)	4.60 (117)	0.59 (15)	1.14 (29)	0.35 (9)	1.22 (31)	1.00 (25)	0.71 (0.32)	0.93 (0.42)
EBV-75-2-x	3/4	20	4.9-15.3	4.2-13.2	2.28 (68)	4.74 (120.5)	0.59 (15)	1.14 (29)	0.35 (9)	1.30 (33)	1.22 (31)	0.75 (0.34)	1.15 (0.52)
EBV-1-2-x	1	25	7.8-29.9	6.7-25.9	3.27 (83)	5.45 (138.5)	0.79 (20)	1.30 (33)	0.36 (9.1)	1.56 (39.7)	1.50 (38)	1.30 (0.59)	1.76 (0.80)
EBV-125-2-x	1-1/4	32	11.7-44.8	10.1-38.8	3.66 (93)	-	0.98 (25)	1.59 (40.5)	0.36 (9.15)	1.79 (45.5)	1.89 (48)	2.05 (0.93)	-
EBV-150-2-x	1-1/2	40	19.6-48.3	17.0-41.8	3.94 (100)	-	1.06 (27)	1.67 (42.5)	0.36 (9.15)	1.93 (49)	2.13 (54)	2.73 (1.24)	-
EBV-2-2-x	2	50	29.2-95.5	25.3-82.6	4.61 (117)	-	1.46 (37)	1.93 (49)	0.35 (9)	2.24 (57)	2.68 (68)	4.61 (2.09)	-

x = Cv

3-WAY

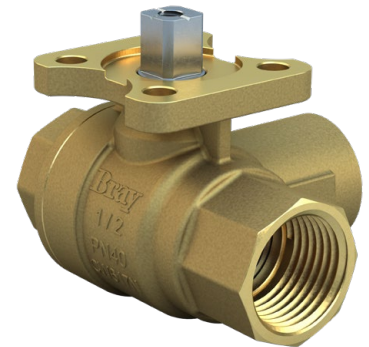
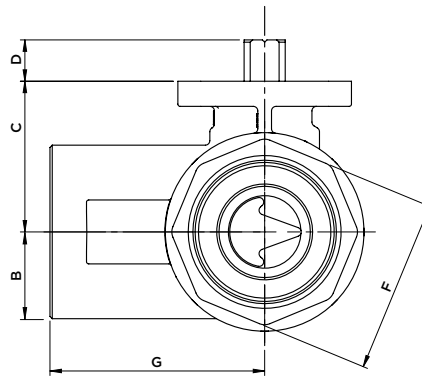
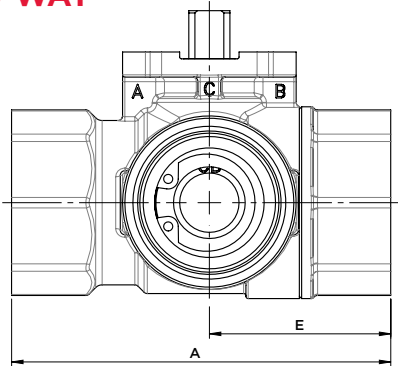

3-WAY - VALVE BODY DIMENSIONS in. (mm)

EBV Valve Model # Prefix	Size		Flow Coefficient		A (NPT)	A (SWEAT/PRESS)	B	C	D	E	F	G (NPT)	G (SWEAT/PRESS)	Weights - lbs. (kg)	
	in.	mm	Cv	Kv										NPT	SWEAT/PRESS
EBV-05-3-x	1/2	15	0.3-17.2	0.3-14.9	2.60 (66)	4.60 (117)	0.59 (15)	1.14 (29)	0.35 (9)	1.22 (31)	1.00 (25)	1.46 (37)	1.93 (49)	0.79 (0.36)	1.12 (0.51)
EBV-75-3-x	3/4	20	4.9-15.3	4.2-13.2	2.28 (68)	4.74 (120.5)	0.59 (15)	1.14 (29)	0.35 (9)	1.30 (33)	1.22 (31)	1.50 (38)	1.93 (49)	0.93 (0.42)	1.59 (0.72)
EBV-1-3-x	1	25	7.8-29.9	6.7-25.9	3.27 (83)	5.45 (138.5)	0.79 (20)	1.30 (33)	0.36 (9.1)	1.56 (39.7)	1.50 (38)	1.85 (47)	2.15 (54.7)	1.59 (0.72)	2.47 (1.12)
EBV-125-3-x	1-1/4	32	11.7-44.8	10.1-38.8	3.66 (93)	-	0.98 (25)	1.59 (40.5)	0.36 (9.15)	1.79 (45.5)	1.89 (48)	2.07 (52.5)	-	2.56 (1.16)	-
EBV-150-3-x	1-1/2	40	19.6-48.3	17.0-41.8	3.94 (100)	-	1.06 (27)	1.67 (42.5)	0.36 (9.15)	1.93 (49)	2.13 (54)	2.19 (55.5)	-	3.37 (1.53)	-
EBV-2-3-x	2	50	29.2-95.5	25.3-82.6	4.61 (117)	-	1.46 (37)	1.93 (49)	0.35 (9)	2.24 (57)	2.68 (68)	2.56 (65)	-	5.80 (2.63)	-

x = Cv