

Simple Set™ Pressure Independent Control Valves 2-Way – 1/2" - 2"

DOCUMENT	
CONTENTS	Features
	Specifications
	Wiring
	Piping Geometry
	Dimensions
LOOKING FOR MORE	Flow Rate Charts
	
© 2026 Bray International, Inc. 05/13/26	

Application

The Bray Simple Set™ is a threaded pressure independent control (PIC) valve designed for a wide variety of hot water and chilled water control applications. The SS Series combines high rangeability control and dynamic balancing into a single compact housing, eliminating the material, installation and commissioning costs of a separate balancing component.

The maximum flow rate is easily set by hand with an adjustment on the top of the valve. The unique design of the Simple Set provides full stroke of the control element, even when the flow rate setting is a small percentage of the maximum flow capacity of the valve.

Simple Set valves achieve a continuous flow rate at any fixed position of the valve irrespective of inlet pressure change. This prevents overflow at any load condition, which contributes to optimal coil performance and primary equipment efficiency.



System Types

Fan Coils, VAV Reheat Coils, Chilled Beams, Computer Room Air Conditioning Units and Air Handling Units.

Features and Benefits

- **Brass Housing with High Flow Cavity**

Robust design, resistant to high temperatures and moderate levels of particulate.

- **Low Pressure Drop**

Reduces pump head requirements for added energy efficiency.

- **Long Stroke**

Provides greater controllability.

- **No minimum straight pipe lengths required before or after the valve**

Provides for maximum piping flexibility, even in crowded mechanical rooms.

Simple Set - Valve Body Specifications

Technical Specifications - Valve Body		
Service	Hot Water, Chilled Water, Up to 50% Glycol	
Size Range	2-Way - 1/2" through 2" (DN 15 to 50)	
Body Cold Working Pressure Ratings	375 psi (25 Bar)	
Media Temperature Range	32°F to 248°F (0°C to 120°C)	
Operational ΔP	Minimum	Varies by size. See pages SS-10 & SS-11
	Maximum	58 psid (400kPa)
Max. Close-Off Pressure	58 psid (400kPa)	
Valve Operation	Push Down to Close, Normally Open	
Shut-Off Leakage	ANSI Class IV (0.01%)	
Stroke	1/2" to 1-1/4" = 0.22" (5.5mm) 1.5" to 2" = 0.59" (15mm)	
Rangeability	>100:1	
End Connections	NPT Threaded	
Materials	Body	DZR Brass
	Flow Regulation Unit	PPS 40% Glass
	Diaphragm	HNBR
	Spring	Stainless Steel
	O-Rings	EPDM
Weights (Valve Body Only)	1/2"	1.98 lb. (.90 kg)
	3/4"	1.98 lb. (.90 kg)
	1"	2.21 lb. (1.00 kg)
	1-1/4"	3.35 lb. (1.60 kg)
	1-1/2"	6.34 lb. (2.90 kg)
	2"	8.70 lb. (4.00 kg)
Warranty	5 Years limited from time of shipment.	
Approvals & Certifications	PED 2014/68/EU, ROHS 2011/65/EU	

Disclaimer - The performance specifications are nominal and conform to acceptable industry standards. For application at conditions beyond these specifications, consult the local Bray office. Bray, Inc. shall not be liable for damages resulting from misapplication or misuse of its products.

Auto-Stroke Settings for Modulating (Analog) - (PAM Series)

Analog actuators perform an Auto-Stroke sequence upon every power-up. The Auto-Stroke sequence runs from 0 to the end position and back in order to automatically detect the stroke limits and calibrate the input signal to the detected stroke limits. The Auto-Stroke sequence can take up to a maximum of 2 minutes to complete.



If the actuator and/or adaptor are removed from the valve after initial installation, an Auto-Stroke sequence must be initiated to recalibrate the actuator. To do so, remove and reapply the power.

Notice

During the Auto-Stroke sequence, the status LED remains on and the actuator will not perform any other action.

Simple Set - Actuator Specifications

Technical Specifications - Actuators						
Actuator Models	For Valves Sizes 1/2" to 1-1/4"				For Valves Sizes 1.5" to 2"	
	PA24-27	PA24-27-FS	PAM24-27	PAM24-27-FS	PAM24-100	PAM24-100-FS
	On/Off & Floating		Modulating		On/Off, Floating & Modulating	
	Non-Fail Safe	Fail Safe	Non-Fail Safe	Fail Safe	Non-Fail Safe	Fail Safe
Supply Voltage	22 to 26 AC/DC				22 to 26 VAC or 28 to 32 VDC	
Power Consumption	5VA	10VA	5VA	10VA	6VA	6VA, 20VA Start Up
Control Signal	2 Position On/Off or 3-Point Floating		Analog, 0-10VDC or 2-10VDC; 4-20mA with external 500Ω resistor		2 Position On/Off (Digital-Pulse Width Modulation), 3 Point Floating, Modulating (Analog), 2-10VDC; 4-20mA	
Input Impedance	4.7 K		10.0 K	100.0 K	100.0 K	
Feedback Signal	No		0-10VDC or 2-10VDC		4 to 20 mA or 2 to 10VDC adjustable	
Failsafe Function	No	Yes (60 Sec. Runtime)	No	Yes (60 Sec. Runtime)	No	Yes (60 Sec. Runtime)
Anti-Stick	No		Optional ¹		Yes	
Operation Time	120 Seconds				90 Seconds	
Enclosure Rating	NEMA type 3R (Equivalent to IP54)					
Ambient Temperature	36°F to 122°F (2°C to 50°C)				0°F to 122° (-18°C to 50°C)	
Humidity Rating	5 to 95% RH Non Condensing					
Connection	3 wires 18 AWG halogen free cable, 3.2 ft.	4 wires 18 AWG halogen free cable, 3.2 ft.			Terminal Connection. Use 18 AWG Minimum	
Noise Rating	>35dBA					
Dimensions	(L) 4.09" x (W) 2.08" x (H) 3.62"			(L) 4.09" x (W) 2.08" x (H) 4.18"	(L) 4.80" x (W) 3.60" x (H) 6.93"	
Weight	0.9 lb. (0.4 kg)				2.0 lb. (0.9 kg)	
Warranty	5 Years limited from time of shipment					
Agency Listing	UL, C E					

¹Anti-Stick Option

With the anti-stick option activated, the actuator will make one full cycle every 24 hours, if the actuator constantly has been in fully open or fully closed position during the previous 24 hours. This operation will clear up any possible impurities accumulated in the valve, and re-calculate the end positions.

Simple Set - Piping Diagram

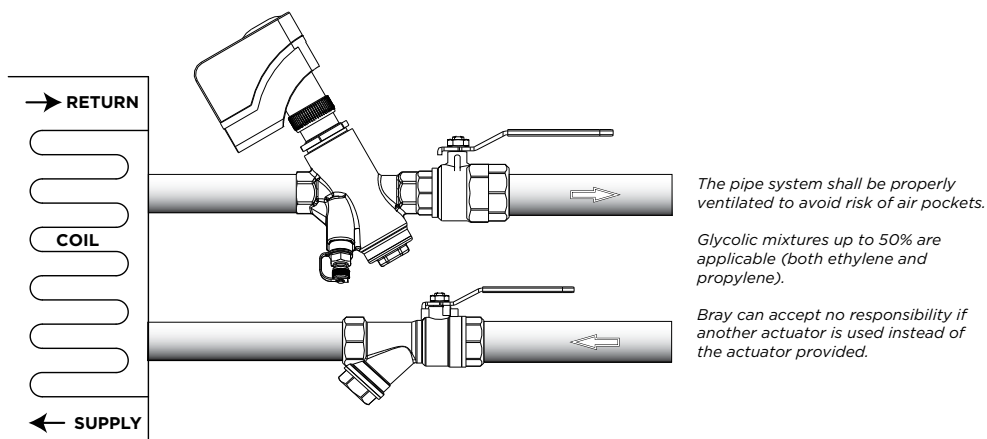

Simple Set - Actuator Wiring

WIRING - (CABLE)



DIP SWITCHES

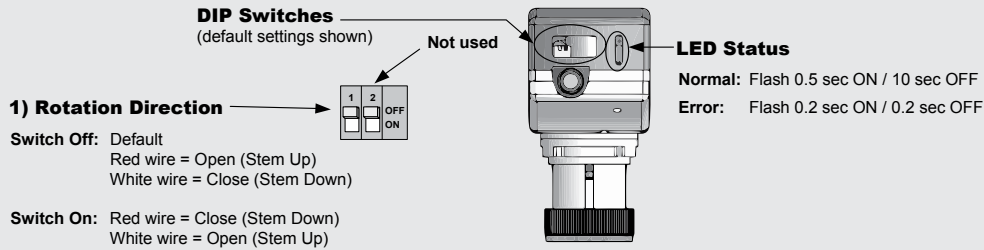

NOTE: For additional operating information consult PA24-27 IOM Manual. The performance specifications are nominal and conform to acceptable industry standards. For application at conditions beyond these specifications, consult the nearest Bray office. Bray controls shall not be liable for damages resulting from misapplication or misuse of its products.

WIRING - (CABLE)



DIP SWITCHES

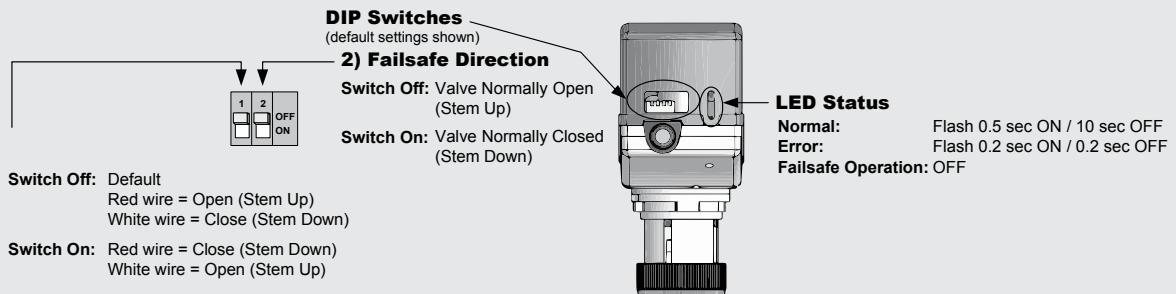

NOTE: The Enerdrive system is a patented method of storing energy (using super capacitors) that is later used to drive the actuator to its failsafe position during a power failure. For additional operating information consult PA24-27 IOM Manual. The performance specifications are nominal and conform to acceptable industry standards. For application at conditions beyond these specifications, consult the nearest Bray office. Bray controls shall not be liable for damages resulting from misapplication or misuse of its products.

Simple Set - Actuator Wiring

WIRING - (CABLE)

PAM24-27 (27 lb force)
MODULATING (ANALOG), NON-FAILSAFE

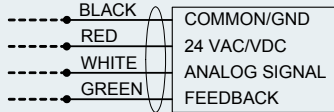

DIP SWITCHES

1) Rotation Direction

Switch Off: Default
 Valve Open
 (Stem Up) - (0 VDC)

Switch On: Valve Closed
 (Stem Down) - (0 VDC)

2) Anti-Stick System

Switch Off: Deactivated
 Switch On: Activated

DIP Switches
 (default settings shown)



3) Input Analog - Signal & Feedback

Switch Off: 2-10 VDC
 Switch On: 0-10 VDC

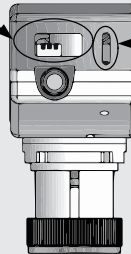

LED Status

Normal: Flash 0.5 sec ON / 10 sec OFF
 Error: Flash 0.2 sec ON / 0.2 sec OFF
 Auto stroke: Continuous ON

NOTE: For additional operating information consult PAM24-27 IOM Manual. The performance specifications are nominal and conform to acceptable industry standards. For application at conditions beyond these specifications, consult the nearest Bray office. Bray controls shall not be liable for damages resulting from misapplication or misuse of its products.

WIRING - (CABLE)

PAM24-27-FS (27 lb force)
MODULATING (ANALOG), FAILSAFE

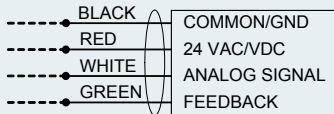

FAILSAFE
 CONTROLLED
 BY DIP
 SWITCHES

DIP SWITCHES

1) Rotation Direction

Switch Off: Default
 Valve Open
 (Stem Up) - (0VDC)

Switch On: Valve Closed
 (Stem Down) - (0VDC)

2) Anti-Stick System

Switch Off: Deactivated
 Switch On: Activated

DIP Switches
 (default settings shown)



4) Failsafe Direction

Switch Off: Valve Normally Open
 (Stem Up)
 Switch On: Valve Normally Closed
 (Stem Down)

3) Input Analog - Signal & Feedback

Switch Off: 2-10 VDC
 Switch On: 0-10 VDC

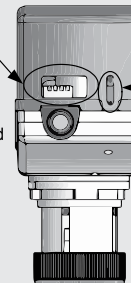

LED Status

Normal: Flash 0.5 sec ON / 10 sec OFF
 Error: Flash 0.2 sec ON / 0.2 sec OFF
 Auto stroke: Continuous ON
 Failsafe charge: Continuous ON
 Failsafe operation: OFF

NOTE: The Enerdrive system is a patented method of storing energy (using super capacitors) that is later used to drive the actuator to it failsafe position during a power failure. For additional operating information consult PAM24-27 IOM Manual. The performance specifications are nominal and conform to acceptable industry standards. For application at conditions beyond these specifications, consult the nearest Bray office. Bray controls shall not be liable for damages resulting from misapplication or misuse of its products.

Simple Set - Actuator Wiring

WIRING - (TERMINAL)

PAM24-100 (100 lb force)
ON/OFF, FLOATING & MODULATING (ANALOG) , NON-FAILSAFE

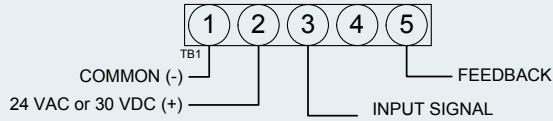

DIGITAL SIGNAL

3 WIRE / 2 POSITION ON/OFF	4 WIRE / 3 POINT FLOATING
-----------------------------------	----------------------------------

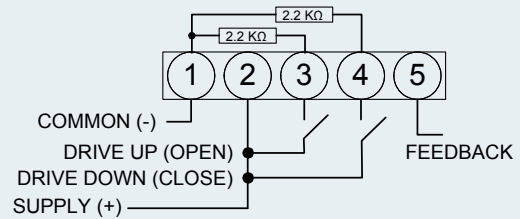
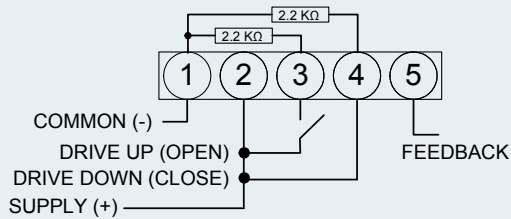

Special Consideration for Digital Control

In this mode, the actuator is sensitive to induced electrical voltages **from external sources**. To prevent such interference, if the signal on pins 4 and 3 on TB1 are from an **external 24VAC source**, install a resistor 2.2kohm, 0.5W between pins 4 and 1 and another of 2.2kohms, 0.5W between pins 3 and 1 of TB1. These resistors are included.

NOTE: For additional operating information consult PAM24-100 IOM Manual. The performance specifications are nominal and conform to acceptable industry standards. For application at conditions beyond these specifications, consult the nearest Bray office. Bray controls shall not be liable for damages resulting from misapplication or misuse of its products.

DIP SWITCHES - DIGITAL SIGNAL

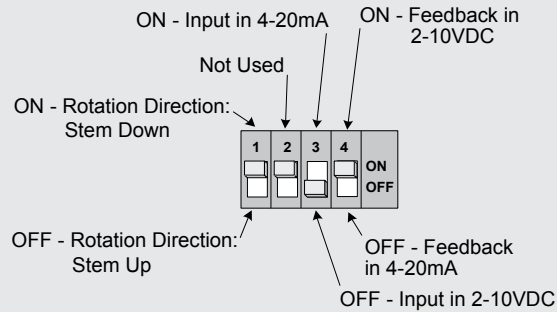

Simple Set - Actuator Wiring

WIRING - (TERMINAL)

PAM24-100-FS (100 lb force)

ON/OFF, FLOATING & MODULATING (ANALOG) ,FAILSAFE

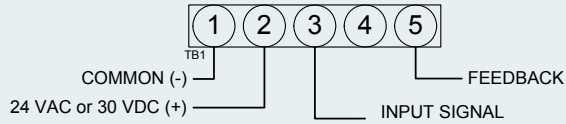

DIGITAL SIGNAL

3 WIRE / 2 POSITION ON/OFF

4 WIRE / 3 POINT FLOATING

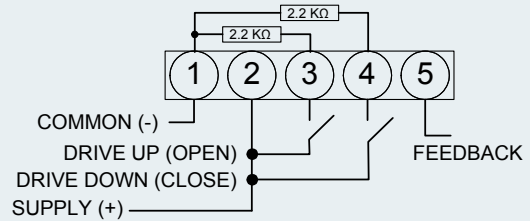
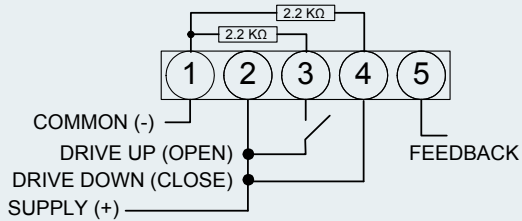

Special Consideration for Digital Control

In this mode, the actuator is sensitive to induced electrical voltages **from external sources**. To prevent such interference, if the signal on pins 4 and 3 on TB1 are from an **external 24VAC source**, install a resistor 2.2kohm, 0.5W between pins 4 and 1 and another of 2.2kohms, 0.5W between pins 3 and 1 of TB1. These resistors are included.

NOTE: The Enerdrive system is a patented method of storing energy (using super capacitors) that is later used to drive the actuator to it failsafe position during a power failure. For additional operating information consult PAM24-100 IOM Manual. The performance specifications are nominal and conform to acceptable industry standards. For application at conditions beyond these specifications, consult the nearest Bray office. Bray controls shall not be liable for damages resulting from misapplication or misuse of its products.

DIP SWITCHES - DIGITAL SIGNAL

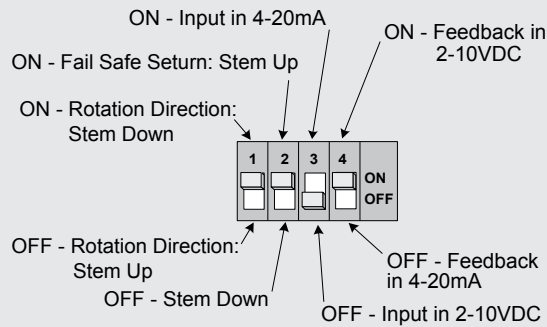

Simple Set - Valve/Actuator Dimensions

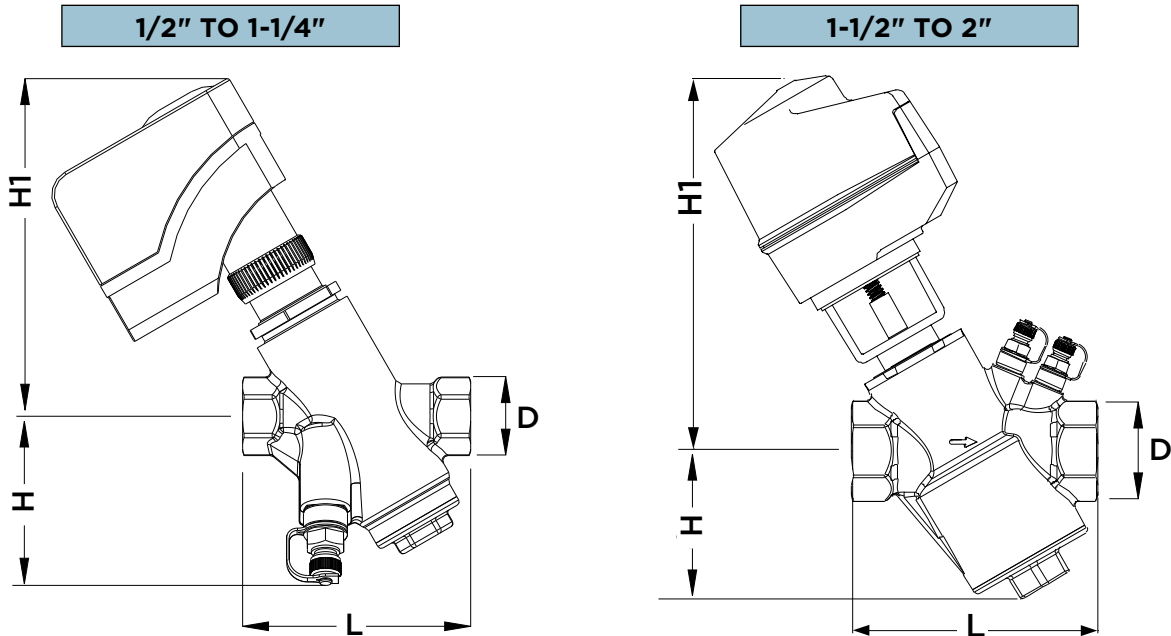

Simple Set - Technical Data and Dimensions

Valve Size			1/2"	3/4"	1"	1-1/4"	1-1/2"	2"
Flow Rate	Liters per hour (l/h)	Low Flow Cartridge	75 - 700	77 - 745	-	-	-	-
		Std. Flow Cartridge	291 - 1576	305 - 1821	400 - 1830	690 - 3000	541 - 7582	596 - 14700
	Gallons per minute (gpm)	Low Flow Cartridge	.3 - 3.1	.3 - 3.3	-	-	-	-
		Std. Flow Cartridge	1.3 - 6.9	1.3 - 8.0	1.8 - 8.1	3.0 - 13.2	2.4 - 33.4	2.6 - 64.7
Dimensions in., (mm)	L		3.62, (92)	3.62, (92)	3.78, (96)	5.0, (128)	5.71, (145)	6.34, (161)
	H		2.68, (68)	2.68, (68)	2.68, (68)	3.03, (77)	3.43, (87)	3.70, (94)
	H1		7.88, (200)	7.88, (200)	7.88, (200)	6.04, (153)	16.00, (406)	15.25, (387)
	D		1.18, (30)	1.42, (36)	1.73, (44)	2.05, (52)	2.33, (59)	3.07, (78)
Weight	lbs., (kg)		2.50, (1.14)	2.50, (1.14)	2.60, (1.18)	4.10, (1.86)	7.90, (3.60)	10.30, (4.70)

Dimensions may vary, depending on the actuator.
 Dimensions are shown for the largest actuator currently available.
 Dimensions are shown in inches and are approximate.

Simple Set - Model Number Matrix

SS Prefix: Simple Set							Valve Series
1		Valve Size (1/2" to 2")					Valve Size
N		End Connections - NPT					End Connections
S		Flow Range Pressure Cartridge - (H) High, (L) Low or (S) Standard					Cartridge
X		Flow Setting GPM. See Charts on Page SS-10 & SS-11					GPM
/							/
		PA24-27		24V On/Off & Floating - Non-Fail Safe			Actuator Selection
		PA24-27-FS		24V On/Off & Floating - Fail Safe			
		PAM24-27		24V Modulating - Non-Fail Safe			
		PAM24-27-FS		24V Modulating - Fail Safe			
		PAM24-100		24V On/Off, Floating & Modulating - Non-Fail Safe			
		PAM24-100-FS		24V On/Off, Floating & Modulating - Fail Safe			
SS	1	N	S	1.8	/	PA24-27	1" Simple Set Body, NPT End Connections, Standard Flow Rate, GPM of 1.8, 24V PA Series Actuator
							Example

Simple Set - How it Works

Function

Unlike conventional control valve sizing where valves are sized to a Cv, the Simple Set valves are simply sized for flow and pipe size. Refer to the ordering table for the wide range of flow values available.

Notice

If valve size differs from pipe size, dP across the valve can not exceed the rating of the valve.

Design

The design of Simple Set combines high performance with small size and compact construction. The main components of the valve are:

Pre-Setting Dial (Detail)

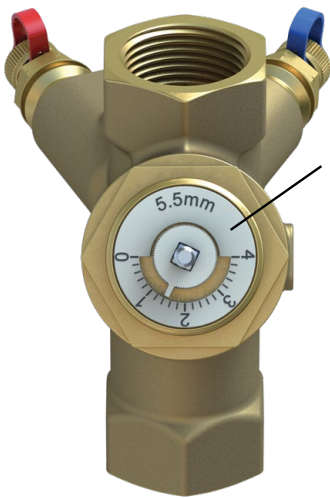

3. Pre-Setting Dial

Sets maximum flow allowed through the valve.

5. Actuator

Reacts to building controller call for more or less flow.



1. Pressure Control Cartridge

Ensures constant flow rate is achieved under fluctuating system pressures. As the system differential pressure increases and decreases, the D_p controller absorbs and releases pressure through an internal capillary tube maintaining a constant D_p across the valve.

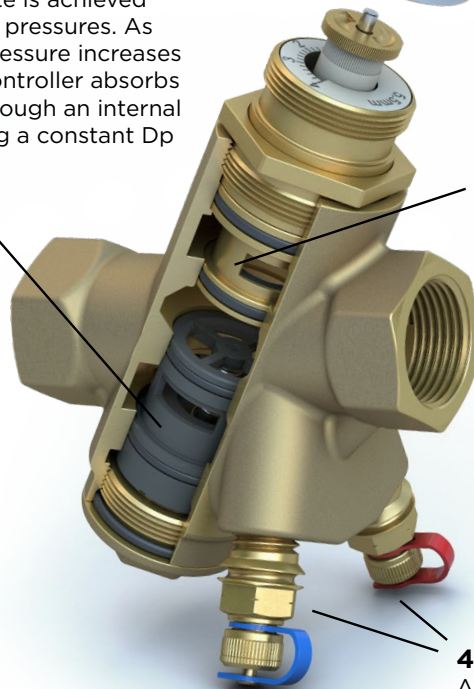

2. Modulating Control Component

1. Rotates laterally to limit max flow through the valve per the Pre-Setting Scale.
2. Moves vertically in response to the actuator call for more or less flow.

4. P/T Plugs

Allows for measurement of pressure and temperature.

Simple Set - Flow Rate Charts

1/2"		1/2" Low Flow Rate Cartridge		
Model Number	Pre-Set	Min. Delta P (psid)	Flow l/h	Flow GPM
SS-050-N-L-0.3	0.3	2.2	75.0	0.3
SS-050-N-L-0.4	0.4	2.2	81.8	0.4
SS-050-N-L-0.5	0.6	2.2	106.7	0.5
SS-050-N-L-0.6	0.8	2.2	134.0	0.6
SS-050-N-L-0.7	1	2.2	161.3	0.7
SS-050-N-L-0.8	1.2	2.5	190.8	0.8
SS-050-N-L-1.0	1.4	2.5	222.6	1.0
SS-050-N-L-1.1	1.6	2.5	256.7	1.1
SS-050-N-L-1.3	1.8	2.5	290.7	1.3
SS-050-N-L-1.4	2	2.5	327.1	1.4
SS-050-N-L-1.6	2.2	2.5	365.7	1.6
SS-050-N-L-1.8	2.4	2.5	404.3	1.8
SS-050-N-L-2.0	2.6	2.5	442.9	2.0
SS-050-N-L-2.1	2.8	2.5	481.5	2.1
SS-050-N-L-2.3	3	2.5	520.1	2.3
SS-050-N-L-2.5	3.2	2.5	556.5	2.5
SS-050-N-L-2.6	3.4	2.5	592.8	2.6
SS-050-N-L-2.8	3.6	2.5	629.1	2.8
SS-050-N-L-3.0	3.8	2.5	672.3	3.0
SS-050-N-L-3.1	4	2.5	699.5	3.1

1/2"		1/2" Standard Flow Rate Cartridge		
Model Number	Pre-Set	Min. Delta P (psid)	Flow l/h	Flow GPM
SS-050-N-S-1.3	0.3	2.8	291.0	1.3
SS-050-N-S-1.4	0.4	2.8	308.0	1.4
SS-050-N-S-1.7	0.6	2.8	378.0	1.7
SS-050-N-S-2.0	0.8	2.8	459.0	2.0
SS-050-N-S-2.5	1	2.8	575.0	2.5
SS-050-N-S-2.9	1.2	2.8	654.0	2.9
SS-050-N-S-3.4	1.4	2.8	765.0	3.4
SS-050-N-S-3.9	1.6	2.9	875.0	3.9
SS-050-N-S-4.3	1.8	2.9	977.0	4.3
SS-050-N-S-4.7	2	2.9	1066.0	4.7
SS-050-N-S-5.0	2.2	3.0	1145.0	5.0
SS-050-N-S-5.3	2.4	3.0	1213.0	5.3
SS-050-N-S-5.6	2.6	3.0	1274.0	5.6
SS-050-N-S-5.9	2.8	3.0	1329.0	5.9
SS-050-N-S-6.1	3	3.0	1390.0	6.1
SS-050-N-S-6.3	3.2	3.1	1424.0	6.3
SS-050-N-S-6.5	3.4	3.2	1466.0	6.5
SS-050-N-S-6.6	3.6	3.2	1505.0	6.6
SS-050-N-S-6.8	3.8	3.3	1542.0	6.8
SS-050-N-S-6.9	4	3.3	1576.0	6.9

3/4"		3/4" Low Flow Rate Cartridge		
Model Number	Pre-Set	Min. Delta P (psid)	Flow l/h	Flow GPM
SS-075-N-L-0.3	0.3	2.3	77.2	0.3
SS-075-N-L-0.4	0.4	2.3	81.8	0.4
SS-075-N-L-0.5	0.6	2.3	106.7	0.5
SS-075-N-L-0.6	0.8	2.3	136.3	0.6
SS-075-N-L-0.7	1	2.3	168.1	0.7
SS-075-N-L-0.9	1.2	2.6	197.6	0.9
SS-075-N-L-1.0	1.4	2.6	227.1	1.0
SS-075-N-L-1.2	1.6	2.6	268.0	1.2
SS-075-N-L-1.3	1.8	2.6	304.3	1.3
SS-075-N-L-1.5	2	2.6	345.2	1.5
SS-075-N-L-1.7	2.2	2.6	388.4	1.7
SS-075-N-L-1.9	2.4	2.6	431.5	1.9
SS-075-N-L-2.1	2.6	2.6	474.7	2.1
SS-075-N-L-2.3	2.8	2.6	517.8	2.3
SS-075-N-L-2.5	3	2.6	567.8	2.5
SS-075-N-L-2.6	3.2	2.6	599.6	2.6
SS-075-N-L-2.8	3.4	2.6	635.9	2.8
SS-075-N-L-3.0	3.6	2.6	672.3	3.0
SS-075-N-L-3.1	3.8	2.6	706.4	3.1
SS-075-N-L-3.3	4	2.6	745.0	3.3

3/4"		3/4" Standard Flow Rate Cartridge		
Model Number	Pre-Set	Min. Delta P (psid)	Flow l/h	Flow GPM
SS-075-N-S-1.3	0.3	2.8	305.0	1.3
SS-075-N-S-1.5	0.4	2.8	333.0	1.5
SS-075-N-S-1.8	0.6	2.9	406.0	1.8
SS-075-N-S-2.1	0.8	3	487.0	2.1
SS-075-N-S-2.6	1	3.2	598.0	2.6
SS-075-N-S-3.0	1.2	3.2	672.0	3.0
SS-075-N-S-3.4	1.4	3.2	775.0	3.4
SS-075-N-S-3.9	1.6	3.2	884.0	3.9
SS-075-N-S-4.4	1.8	3.2	993.0	4.4
SS-075-N-S-4.8	2	3.2	1100.0	4.8
SS-075-N-S-5.3	2.2	3.2	1201.0	5.3
SS-075-N-S-5.7	2.4	3.2	1294.0	5.7
SS-075-N-S-6.1	2.6	3.2	1379.0	6.1
SS-075-N-S-6.4	2.8	3.2	1457.0	6.4
SS-075-N-S-6.8	3	3.2	1544.0	6.8
SS-075-N-S-7.0	3.2	3.2	1593.0	7.0
SS-075-N-S-7.3	3.4	3.2	1653.0	7.3
SS-075-N-S-7.5	3.6	3.3	1709.0	7.5
SS-075-N-S-7.8	3.8	3.3	1761.0	7.8
SS-075-N-S-8.0	4	3.3	1821.0	8.0

Note: Min. Delta P Available at Selected Flow Rate.
See Website for Specific Flow Rate Settings Calculator

Simple Set - Flow Rate Charts

1"		1" Standard Flow Rate Cartridge		
Model Number	Pre-Set	Min. Delta P (psid)	Flow l/h	Flow GPM
SS-1-N-S-1.8	0.3	3.9	400.0	1.8
SS-1-N-S-1.8	0.4	3.9	414.0	1.8
SS-1-N-S-2.1	0.6	3.9	470.0	2.1
SS-1-N-S-2.3	0.8	3.9	532.0	2.3
SS-1-N-S-2.7	1	3.9	618.0	2.7
SS-1-N-S-3.0	1.2	3.9	676.0	3.0
SS-1-N-S-3.4	1.4	3.9	762.0	3.4
SS-1-N-S-3.8	1.6	4	857.0	3.8
SS-1-N-S-4.2	1.8	4	961.0	4.2
SS-1-N-S-4.7	2	4	1071.0	4.7
SS-1-N-S-5.2	2.2	4	1182.0	5.2
SS-1-N-S-5.7	2.4	4	1286.0	5.7
SS-1-N-S-6.1	2.6	4	1381.0	6.1
SS-1-N-S-6.5	2.8	4	1467.0	6.5
SS-1-N-S-6.9	3	4.1	1560.0	6.9
SS-1-N-S-7.1	3.2	4.1	1611.0	7.1
SS-1-N-S-7.4	3.4	4.2	1673.0	7.4
SS-1-N-S-7.6	3.6	4.3	1730.0	7.6
SS-1-N-S-7.8	3.8	4.4	1781.0	7.8
SS-1-N-S-8.1	4	4.5	1830.0	8.1

1-1/4"		1-1/4" Standard Flow Rate Cartridge		
Model Number	Pre-Set	Min. Delta P (psid)	Flow l/h	Flow GPM
SS-125-N-S-3.0	0.3	3	690.0	3.0
SS-125-N-S-3.2	0.4	3.1	735.0	3.2
SS-125-N-S-4.0	0.6	3.1	910.0	4.0
SS-125-N-S-4.8	0.8	3.1	1079.0	4.8
SS-125-N-S-5.5	1	3.2	1245.0	5.5
SS-125-N-S-6.2	1.2	3.2	1406.0	6.2
SS-125-N-S-6.9	1.4	3.2	1564.0	6.9
SS-125-N-S-7.6	1.6	3.2	1718.0	7.6
SS-125-N-S-8.2	1.8	3.2	1869.0	8.2
SS-125-N-S-8.9	2	3.2	2017.0	8.9
SS-125-N-S-9.5	2.2	3.2	2162.0	9.5
SS-125-N-S-10.1	2.4	3.2	2304.0	10.1
SS-125-N-S-10.8	2.6	3.2	2444.0	10.8
SS-125-N-S-11.4	2.8	3.2	2581.0	11.4
SS-125-N-S-12.1	3	3.2	2748.0	12.1
SS-125-N-S-12.3	3.2	3.2	2787.0	12.3
SS-125-N-S-12.5	3.4	3.3	2837.0	12.5
SS-125-N-S-12.7	3.6	3.3	2887.0	12.7
SS-125-N-S-12.9	3.8	3.4	2938.0	12.9
SS-125-N-S-13.2	4	3.5	3000.0	13.2

1-1/2"		1-1/2" Standard Flow Rate Cartridge		
Model Number	Pre-Set	Min. Delta P (psid)	Flow l/h	Flow GPM
SS-150-N-S-2.4	0.3	3.0	541.0	2.4
SS-150-N-S-3.1	0.4	3.0	695.0	3.1
SS-150-N-S-5.7	0.6	3.0	1291.0	5.7
SS-150-N-S-8.2	0.8	3.0	1856.0	8.2
SS-150-N-S-10.9	1	3.0	2480.0	10.9
SS-150-N-S-12.8	1.2	3.1	2912.0	12.8
SS-150-N-S-15.0	1.4	3.2	3409.0	15.0
SS-150-N-S-17.1	1.6	3.4	3887.0	17.1
SS-150-N-S-19.1	1.8	3.5	4346.0	19.1
SS-150-N-S-21.1	2	3.6	4797.0	21.1
SS-150-N-S-23.0	2.2	3.7	5231.0	23.0
SS-150-N-S-24.9	2.4	3.8	5653.0	24.9
SS-150-N-S-26.7	2.6	3.9	6064.0	26.7
SS-150-N-S-28.5	2.8	3.9	6465.0	28.5
SS-150-N-S-30.3	3	4.0	6875.0	30.3
SS-150-N-S-31.0	3.2	4.2	7051.0	31.0
SS-150-N-S-31.6	3.4	4.4	7183.0	31.6
SS-150-N-S-32.2	3.6	4.5	7315.0	32.2
SS-150-N-S-32.8	3.8	4.7	7447.0	32.8
SS-150-N-S-33.4	4	4.9	7582	33.4

2"		2" Standard Flow Rate Cartridge		
Model Number	Pre-Set	Min. Delta P (psid)	Flow l/h	Flow GPM
SS-2-N-S-2.6	0.3	4.9	596.0	2.6
SS-2-N-S-3.5	0.4	4.9	797.0	3.5
SS-2-N-S-7.1	0.6	4.9	1613.0	7.1
SS-2-N-S-10.8	0.8	4.9	2449.0	10.8
SS-2-N-S-15.5	1	4.9	3514.0	15.5
SS-2-N-S-18.3	1.2	4.9	4161.0	18.3
SS-2-N-S-22.1	1.4	4.9	5025.0	22.1
SS-2-N-S-25.9	1.6	4.9	5885.0	25.9
SS-2-N-S-29.7	1.8	4.9	6736.0	29.7
SS-2-N-S-33.3	2	4.9	7572.0	33.3
SS-2-N-S-36.9	2.2	4.9	8387.0	36.9
SS-2-N-S-40.4	2.4	4.9	9180.0	40.4
SS-2-N-S-43.8	2.6	4.9	9946.0	43.8
SS-2-N-S-47.1	2.8	4.9	10686.0	47.1
SS-2-N-S-50.9	3	4.9	11568.0	50.9
SS-2-N-S-53.2	3.2	5.0	12082.0	53.2
SS-2-N-S-56.1	3.4	5.1	12740.0	56.1
SS-2-N-S-58.9	3.6	5.3	13372.0	58.9
SS-2-N-S-61.6	3.8	5.4	13988.0	61.6
SS-2-N-S-64.7	4	5.5	14700.0	64.7

Note: Min. Delta P Available at Selected Flow Rate.
See Website for Specific Flow Rate Settings Calculator

Bray COMMERCIAL

Bray Commercial provides automated Butterfly, Ball, Globe and Pressure Independent Control Valves to the commercial building HVAC market throughout the world. Wherever valve performance is required to maintain climate controlled environments, Bray can provide the required automated valves to meet the demanding flow applications of chiller/boiler isolation, air handlers and terminal units for new construction, retrofit and/or LEED certification applications in buildings.

Building Types

- Healthcare
- Data Centers
- Government and Municipal
- Sports/Entertainment/Convention Centers
- K-12 and University Education
- Transportation
- Hotels
- Office Buildings
- Retail

SINCE 1986, BRAY HAS PROVIDED FLOW CONTROL SOLUTIONS FOR A VARIETY OF INDUSTRIES AROUND THE WORLD.

VISIT BRAYCOMMERCIALDIVISION.COM TO LEARN MORE ABOUT BRAY PRODUCTS AND LOCATIONS NEAR YOU.

CORPORATE HEADQUARTERS

Bray International, Inc.
13333 Westland East Blvd.
Houston, Texas 77041
1-281-894-5454

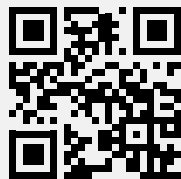

DIVISION HEADQUARTERS

Bray Commercial
13788 West Road, Suite 200A
Houston, Texas 77041
1-888-412-Bray (2729)

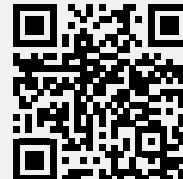

All statements, technical information, and recommendations in this bulletin are for general use only. Consult Bray representatives or factory for the specific requirements and material selection for your intended application. The right to change or modify product design or product without prior notice is reserved. Patents issued and applied for worldwide. Bray® is a registered trademark of Bray International, Inc.

© 2022 BRAY INTERNATIONAL, INC. ALL RIGHTS RESERVED.